

Unwinder u9

Enhanced application flexibility



- ✓ **Speed up to 500 fpm (150 m/min)**
- ✓ **Reliable feeding**
- ✓ **Accommodates broad range of papers**
- ✓ **Maximum printer productivity**
- ✓ **Unattended printing**

Service Area

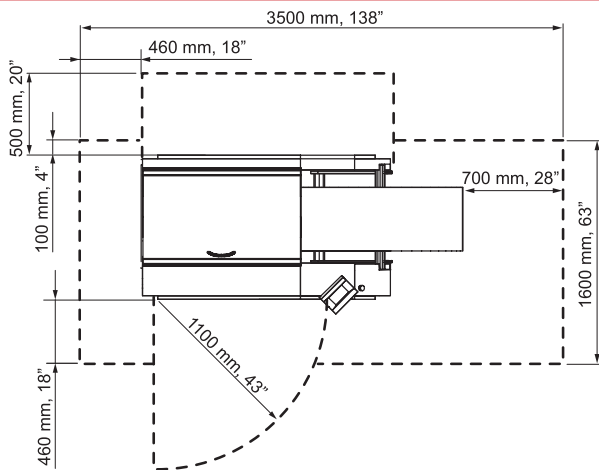

Technical Specifications

Performance / Media

Speed max.	500 ft/min	150 m/min
Feeding	pinfed or pinless	
Web tension	loose or tight	
Paper weight	10.5# bond - 110# cover, 40 - 300 gsm	
Roll diameter	4" - 52"	100 - 1320 mm
Roll weight max.	1389 lbs.	630 kg
Web width	8" - 22"	200 - 559 mm
Core sizes	3", 5", 6"	70, 150, 200 mm

Options

Splice table	convenient transition from rolls
Roll carts	easily move, store and load paper rolls

Electrical

Power	200-240 Vac, 1-phase, 50/60 Hz, 10A
Consumption	1800 W (in use), 120 W (idle)
Heat output	1150 BTU/h, 337 W

Environmental

Temperature	60 - 90° F	15 - 32° C
Acoustics	65 dB(A)	
Humidity	50 ± 10%	

Dimensions

Length (incl. max roll)	95"	2400 mm
Width	41.7"	1060 mm
Height (incl. display)	49.8"	1280 mm
Weight	1830 lb	830 kg
Color	dark grey	

Approvals

CE (2006/42/EC), EMC Class A, LVD,
CB EN 60950, cULus 60950-1,
FCC15 Class A

Product Specification



01032016

©2016 TecnaU. All rights reserved. The TecnaU name and logo are trademarks of TecnaU. TecnaU reserves the right to make any technical amendments without prior notification.



TECNAU
w w w . t e c n a u . c o m

Europe	Italy	+39 0125 631678	info.it@tecnaU.com
	Sweden	+46 372 256 00	info.se@tecnaU.com
Americas	USA	+1 978 608 0500	info.us@tecnaU.com
Asia Pacific	China	+86 159 00710147	info.cn@tecnaU.com
	Singapore	+65 6793 9478	info.sg@tecnaU.com