

# TC 7000 HS

## High speed pinless cutter

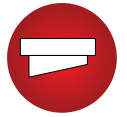

- ✓ **High speeds**
- ✓ **Variable strip cut**
- ✓ **1-up, 2-up and 3-up imposition**
- ✓ **Transpromo & direct mail**

### Service Area

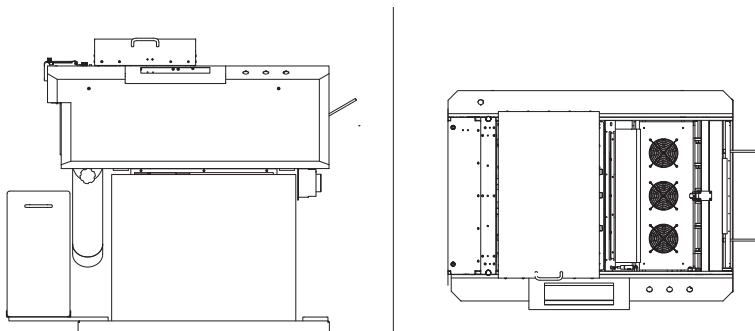

### Technical Specifications

#### Performance / Media

Speed	up to 36.000 cuts/hour with 12" format	
Feeding	pinless or pinfed	
Paper weight	40# text - 100# text ≈ 60 - 150 gsm <i>under 60 gsm requires application review</i>	
Web width	7" - 20"	178 - 510 mm
Form width	3.25" - 19.7"	82 - 500 mm
Form height	min. 3.5"	min. 89 mm
Side Trimming	up to 1" or 2"	up to 25 or 50 mm <i>side trimming is cartridge dependent</i>

#### Electrical

Power	230V/208V, 50/60 Hz, 1,2 KVA
-------	------------------------------

#### Environmental

Temperature	60 - 90° F	15 - 32° C
Acoustics	65 dB(A)	
Humidity	50 ± 10%	

#### Dimensions

Length	49.2"	1250 mm
Width	34.6"	880 mm
Height	44.0"	1120 mm
Weight	496 lb	225 kg

#### Approvals



2014/35/ EU, 2006/42/ EC, 2014/30/ EU  
2011/65/ EU, 2012/19/EU, EN 12100:2010,  
EN 60204-1:2006, EN 61000-6-2:2005,  
EN 61000-6-4:2007, EN 50581:2012

Product Specification



01122015

©2015 Tecna. All rights reserved. The Tecna name and logo are trademarks of Tecna. Tecna reserves the right to make any technical amendments without prior notification.



**TECNAU**  
w w w . t e c n a u . c o m

Europe	Italy	+39 0125 631678	info.it@tecna.com
	Sweden	+46 372 256 00	info.se@tecna.com
Americas	USA	+1 978 608 0500	info.us@tecna.com
Asia Pacific	China	+86 159 00710147	info.cn@tecna.com
	Singapore	+65 6793 9478	info.sg@tecna.com