

Stacker s28

Performance stacking



- ✓ 1, 2, or 3-up with offset
- ✓ Damage-free sheet controls
- ✓ Stack separation
- ✓ Internal stack buffer

Service Area

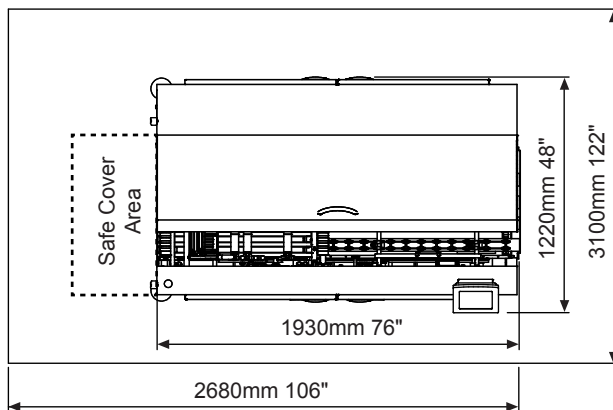

Technical Specifications

Performance / Media

Speed max.	450 ft/min	137 m/min
Feeding	Pinfed or pinless	
Paper weight	14.5# bond - 140# index, 55 - 250 gsm <i>(paper dependent, above 200 gsm requires application review)</i>	
Web width	5.5" - 20.5"	140 mm - 520 mm
Sheet length	3.5" - 28"	90 mm - 711 mm
Stack height	2 cuts - 9.8"	250 mm
Offset	0,6"	15 mm
Delivery height	23.6" - 27.5"	600 mm - 700 mm

Electrical

Power	10A, 200-240 VAC, 50/60 Hz or <i>(North America)</i> 15A, 1 Phase, 208 V, REC=L6-15R	
Consumption	250 W (in use)	70 W (idle)
Heat output	250W	70W

Environmental

Temperature	55 - 95° F	13 - 35° C
Acoustics	70 dB(A)	
Humidity	8 - 80%	

Dimensions

Length	76"	1930 mm
Width	48"	1220 mm
Height excl. display	46"	1170 mm
Weight	≈ 1322 lb	≈ 600 kg
Color	Gray	

Approvals

CE (98/37/EG), EMC Class A, LVD,
CB EN 60950, cULus 1950 3rd,
FCC15 Class A, VCCI

Product Specifications

