



Stack 1250 G

Continuous offset stacking



*The Stack 1250 G solution includes the
Unwinder 550, Merging Modules,
Simpla or Dupla Cutter, Stacker TC 1250 G,
Delivery Table TC 0310 G*

- ✓ **Continuous offset stacking**
- ✓ **Speed up to 425 fpm**
- ✓ **1-up or slit-merge output**
- ✓ **Set by set delivery**

Rely on the Stack 1250 G for performance cutting and stacking from web-fed digital printers. Running at speeds up to 425 feet per minute (130 m/min), the Stack 1250 G is an ideal solution for printers who are looking for flexibility and automation, with a solution which ensure compatibility with both monochrome and color printers for today and tomorrow.

Whatever your printing needs, the versatile Stack 1250 G is your solution. Effortlessly produce print on demand applications as 1-up stacks ready for near line binding. For statements or TransPromo applications, create 2-up merged stacks from pinfed or pinless paper. The Stack 1250 G, can be configured to match your requirements, of cutting, stacking and job offsetting. A broad range of basis weights is supported, from 18# bond to 38# cover (70 to 100 gsm). Stacks are well

spaced for crisp, clean quality and easy removal by the operator to near-line or off-line finishers or inserters.

Tecnau cutters can be equipped with different cartridges with single or double knife -for single cut and strip removal- to support a broad range of applications. Tecnau cartridges have a unique design which enables quick application changeover and easy on site maintenance.

Global service and around-the-clock support help ensure our reputation as the industry's reliability leader. Our products increase productivity, cut labor and paper costs, and even make new applications possible - Tecnau solutions truly empower digital print to help you do more with less.



Stack 1250 G

Continuous offset stacking

The Stack 1250 G solution features the Unwinder 550, Simpla or Dupla Cutter, Stacker TC 1250 G, Delivery Table TC 0310 G, with merging modules before or after cutting depending on the configuration selected.

The center-shaft driven Unwinder 550 feeds a roll of paper up to 20.5" wide and 52" in diameter into the Cutter TC 1000, TC 2x00 or TC 7x00 series, which trim and cut the printed output utilizing a guillotine technology.

The Stacker TC 1250 G builds up to 2.000 sheet stacks, which are delivered to a pack conveyor system when a separation mark is detected by a OMR or 2D code reader.

All components are modular, compact and are designed to dramatically improve work-flow.

As with all of our products, the Stack 1250 G solution is compatible with today's most advanced digital printers and can be adapted to meet your

printing needs. Innovative products combined with award winning support and service make TecnaU the essential partner for your print operation.

Merging Modules

TC 1105 or 7105 Merger

Merge continuous web before cutting with job separation of even number of pages

DLS 101 Dynamic Linear Sequencer

Merge loose sheets after cutting with job separation of even and uneven number of pages.



Merger TC 1105

Technical Specifications

Performance / Media

Speed max	425 ft/min	130 m/min
	<i>(depending on cutter model selected)</i>	
Feeding	Pinfed or Pinless depending on Cutter Models	
Paper weight	18# bond 38# cover 70 - 100 gsm <i>above 100 gsm requires application review</i>	
Web width	16" - 20.5"	406 mm - 520 mm
Form length	4" - 12"	102 mm - 305 mm
Form width	7.8" - 12"	200 - 305 mm
Stack height	10"	250 mm
Offset	up to 1"	up to 25 mm
Strip cut	Single and double cut with interchangeable cartridges	
Output options	1-up, slit merge	

Electrical

Power 230V/208V, 50/60 Hz, 1 KVA

Approvals

2006/95/ CE - 2006/42/ CE - 2004/108/ CE
EN 12100:2010; EN 60204-1:2006;
EN 61000-6-2:2005; EN 61000-6-4:2007

Configuration Examples

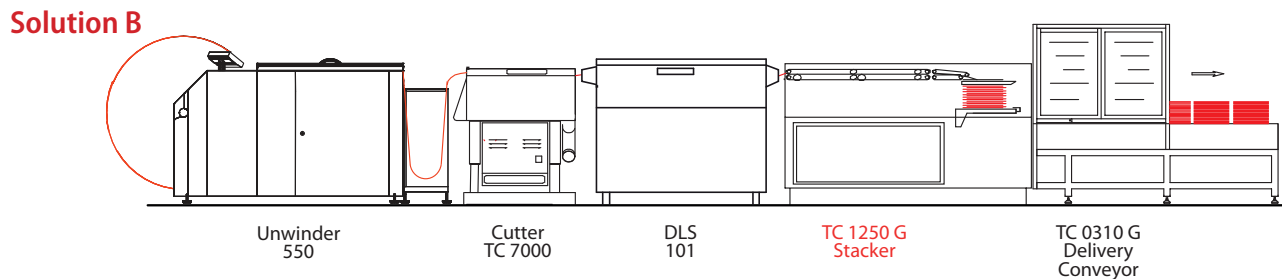
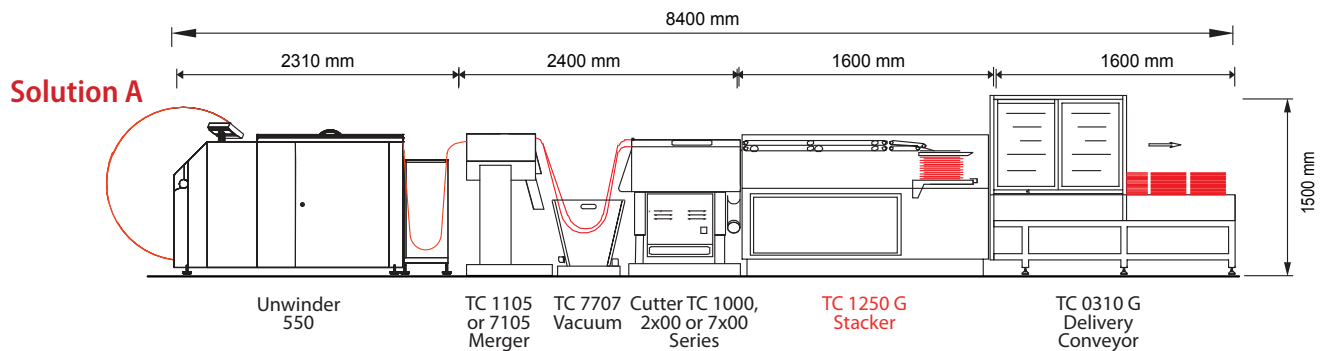

23032016

©2016 TecnaU. All rights reserved. The TecnaU name and logo are trademarks of TecnaU. TecnaU reserves the right to make any technical amendments without prior notification.



TECNAU
w w w . t e c n a u . c o m

Europe	Italy	+39 0125 631678	info.it@tecnaU.com
	Sweden	+46 372 256 00	info.se@tecnaU.com
Americas	USA	+1 978 608 0500	info.us@tecnaU.com
Asia Pacific	China	+86 159 00710147	info.cn@tecnaU.com
	Singapore	+65 6793 9478	info.sg@tecnaU.com