

# Merger m20

## Flexible 2-up slit merge processing



- ✓ *Dynamic center slit justification*
- ✓ *Flexible page size formats*
- ✓ *Easy changeover from slit merge to 2-up or 3-up*
- ✓ *Pinless or pinfed paper*

### Service Area

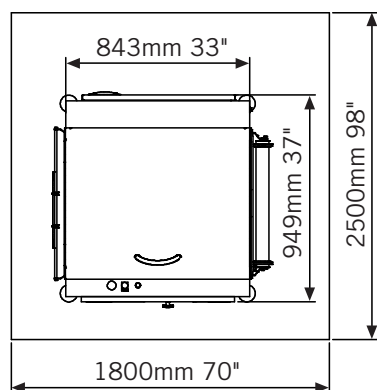

### Technical Specifications

#### Performance / Media

Speed max.	600 ft/min	180 m/min
Feeding	Pinfed or pinless	
Paper weight	40 - 100 gsm	
Web width	5.5" - 20.5"	140 mm - 520 mm
Buffer capacity	21 ft	6.5 m

#### Electrical

Power	10A, 200-240 VAC, 50/60 Hz or (North America) 15A, 1 Phase, 208 V, REC=L6-15R	
Consumption	350 W (in use)	25 W (idle)
Heat output	350 W - 25 W	

#### Environmental

Temperature	55 - 95° F	13 - 35° C
Acoustics	70 dB(A)	
Humidity	8 - 80%	

#### Dimensions

Length	33"	843 mm
Width	37"	949 mm
Height	45.5"	1155 mm
Weight	573 lb	260 kg
Color	Gray	

#### Approvals

CE (98/37/EG), EMC Class A, LVD,  
CB EN 60950, cULus 60950-1,  
FCC15 Class A, VCCI

## Product Specifications



16092014

©2014 TecnaU. All rights reserved. The TecnaU name and logo are trademarks of TecnaU. TecnaU reserves the right to make any technical amendments without prior notification.



**TECNAU**  
w w w . t e c n a u . c o m

Europe	Italy	+39 0125 631678	info.it@tecnau.com
	Sweden	+46 372 256 00	info.se@tecnau.com
Americas	USA	+1 978 608 0500	info.us@tecnau.com
Asia Pacific	China	+86 159 00710147	info.cn@tecnau.com
	Singapore	+65 6793 9478	info.sg@tecnau.com