

Buffer 530

For maximum efficiency



- ✓ Accumulates up to 50 feet of paper
- ✓ Controlled input and output
- ✓ Automatic tension release at long stops
- ✓ Enables continuous printer operation

Service Area

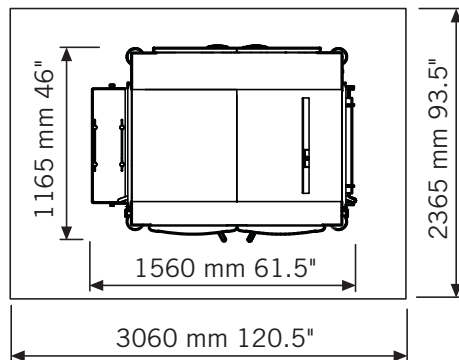

Technical Specifications

Performance / Media

Speed max.	600 ft/min	180 m/min
Feeding	Pinfed or pinless	
Paper weight	10.7# bond - 53# bond index 40 - 200 gsm	
Web width	6" - 20.5"	155 mm - 520 mm
Buffer capacity	50 ft	15 meters

Options

Out-feed loop

Electrical

Power	10A, 200-240 VAC, 50/60 Hz or (North America) 15A, 1 Phase, 208 V, REC=L6-15R	
Consumption	500 W (in use)	120 W (idle)
Heat output	300 kcal/h - 1200 kJ/h - 1194 BTU/h	

Environmental

Temperature	60 - 80° F	15 - 27° C
Acoustics	65 dB(A)	
Humidity	50 +10%	

Dimensions

Length inc. loop	61.5"	1560 mm
Width	46"	1165 mm
Height	63.5"	1610 mm
Weight	880 lb	400 kg
Color	Gray	

Approvals

CE (98/37/EG), EMC Class A, LVD,
CB EN 60950, cULus 60950-1,
FCC15 Class A, VCCI

Product Specifications



25092015

©2014 Tecnau. All rights reserved. The Tecnau name and logo are trademarks of Tecnau. Tecnau reserves the right to make any technical amendments without prior notification.



TECNAU
w w w . t e c n a u . c o m

Europe	Italy	+39 0125 631678	info.it@tecnau.com
	Sweden	+46 372 256 00	info.se@tecnau.com
Americas	USA	+1 978 608 0500	info.us@tecnau.com
Asia Pacific	China	+86 159 00710147	info.cn@tecnau.com
	Singapore	+65 6793 9478	info.sg@tecnau.com