

# Web Merger WM6-Even



## Purpose

The WM6-Even web merger cuts a wide web and merges the two web halves.

## Method of operation

The web from the printer is pulled through the WM6-Even merger by the pinless infeed of the CS6 cutter. The web is cut using a centre cut knife. Both halves of the web are merged using an adjustable turnbar device and the merged web is afterwards cut into sheets by the CS6.

Roll to cut sheet line with LS6:

For printer online applications with speeds up to 60 m/min, a VU6-2100 suffices to buffer the web during a stack separation. For speeds exceeding 60 m/min a WB6 web buffer is required.

## Basic equipment

- Web Merger WM6-Even

## Optional equipment

- Center cut
- Gutter cut
- Edge trimming left
- Edge trimming right
- Exhauster for edge trimming or linear gutter cut
- Electrostatic charging device for chipout with CS6-II

## Technical data

Paper weight: 60–120 g/m<sup>2</sup>  
Paper web width unmerged: 330–520.7 mm 13"–20<sup>1</sup>/<sub>2</sub>"  
Speed: 10–180 m/min.

Main supply via Power-Link from the cutting module

Rated current : 2.5 A  
Effective output : 540 W  
Apparent output : 600 VA  
Heat dissipation : 1843 BTU/h  
Heat dissipation : 1944 kJ/h

Weight: 385 kg

All technical data subject to change

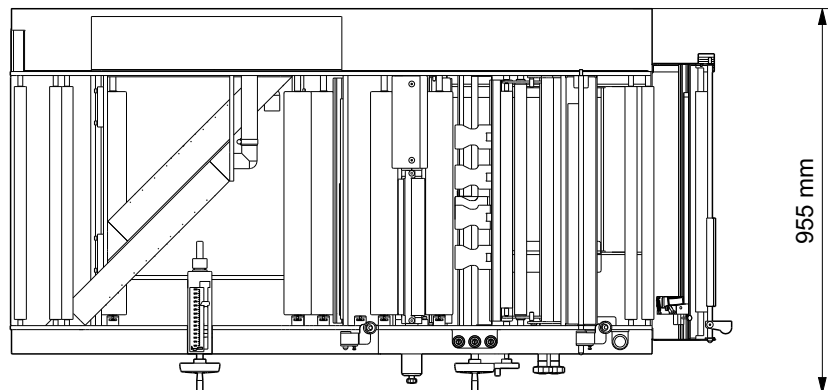
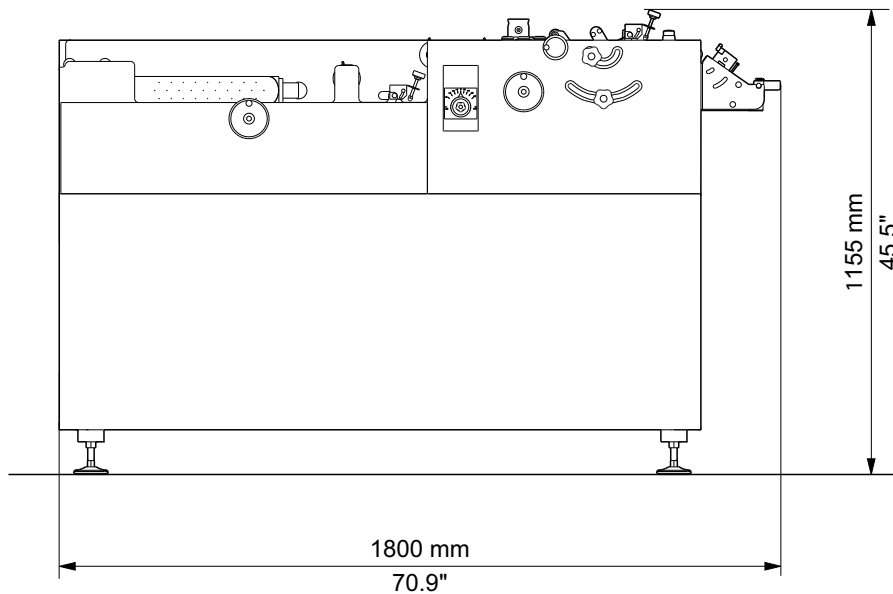

internet: [www.hunkeler.ch](http://www.hunkeler.ch)

e-mail: [info@hunkeler.ch](mailto:info@hunkeler.ch)

### Hunkeler AG

CH-4806 Wikon  
Tel. (+41) 62 745 61 61  
Fax (+41) 62 745 62 76

### Hunkeler Deutschland GmbH

D-82024 Taufkirchen  
Tel. (+49) 89 614 1590  
Fax (+49) 89 612 8400

### Hunkeler Italia Srl.

I-20099 Sesto San Giovanni (MI)  
Tel. (+39) 0226 200 14  
Fax (+39) 0224 411 923

### Hunkeler Far East Ltd.

Wanchai, Hong Kong  
Tel. (+852) 2528 4082  
Fax (+852) 2866 2401