

Unwinder u30

The wide choice



- ✓ High speeds up to 1000 fpm
- ✓ Paper roll up to 30.5" wide
- ✓ Servo roll lift
- ✓ Automatic tension control system
- ✓ New ease of use features

Service Area

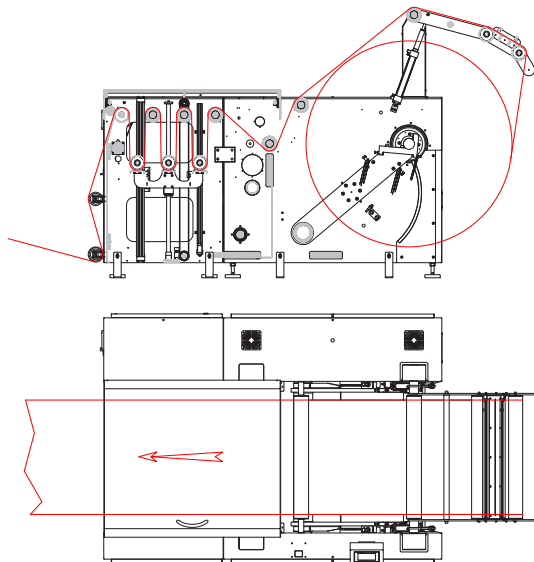

Technical Specifications

Performance / Media

Speed max.	1000 ft/min	300 m/min
Speed control	Electronic controlled	
Feeding	Pinfed or pinless	
Paper weight	28 text - 140 index	40 - 250 gsm
	<i>For paper weights below 50 gsm and above 250 gsm requires application review</i>	
Roll diameter	8" - 54"	200 mm - 1372 mm
Roll weight max.	2946 lb	1350 kg
Web width	up to 30.5"	up to 775 mm
Web tension	Tight	
Core sizes	3", 6"	70, 150, 200 mm
Rotation direction	Selectable	
Accel/deceleration	6 sec minimum	
Buffer capacity	13 ft (26 ft optional)	4 m (8 m optional)
Servo roll lift	Yes	
Sliding chuck	Automatic	
Operator panel	Touch 5.7"	

Options

Roll cart for roll transport, splice station, high capacity buffer, left or right operator side

Electrical

Power	400-480 V, 50/60 Hz, 3 Phase, 20 A
-------	------------------------------------

Environmental

Temperature	60-90° F	15-32° C
Humidity	40 - 60%	
Air requirements	External supply, 6 Bar, dry & filtered	

Dimensions

Length	89"	2250 mm
With long buffer	113"	2870 mm
Width	63"	1600 mm
Height max.	85.5"	2170 mm
Weight	5070 lb	2300 kg

Approvals



2014/35/ EU, 2006/42/ EC, 2014/30/ EU, 2011/65/ EU, 2012/19/EU, EN 12100:2010, EN 60204-1:2006, EN 61000-6-2:2005, EN 61000-6-4:2007, EN 50581:2012



UL 2011, CSA C22.2 No. 14-05, File E302492, GPNY/GPNY7

Product Specifications



01122015

©2015 Tecna. All rights reserved. The Tecna name and logo are trademarks of Tecna. Tecna reserves the right to make any technical amendments without prior notification.



TECNAU
w w w . t e c n a u . c o m

Europe	Italy	+39 0125 631678	info.it@tecna.com
	Sweden	+46 372 256 00	info.se@tecna.com
Americas	USA	+1 978 608 0500	info.us@tecna.com
Asia Pacific	China	+86 159 00710147	info.cn@tecna.com
	Singapore	+65 6793 9478	info.sg@tecna.com