

# Unwinder u20

## Smooth, Fast, and Easy Printed Rolls



- ✓ *High speed - up to 833 fpm*
- ✓ *New ease of use features*
- ✓ *Paper roll up to 22.5" wide*
- ✓ *Automatic tension control system*

### Service Area

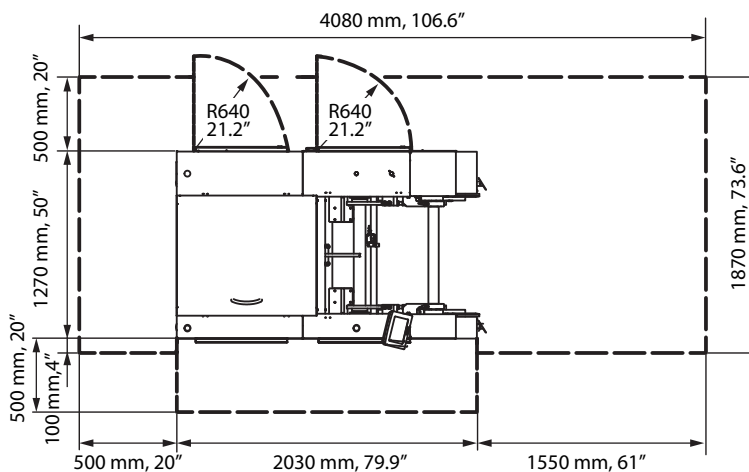

### Technical Specifications

#### Performance / Media

Speed max.	833 ft/min	254 m/min
Feeding	pinfed or pinless	
Paper weight	40 - 300 gsm, 10.5 bond - 167.5 index	
Roll diameter	4" - 52"	100 - 1320 mm
Roll weight max.	1650 lbs.	750 kg
Web width	8" - 22.5"	204 - 572 mm
Core Sizes	3", 5", 6"	70, 150, 200 mm

#### Options

Roll Carts	Easily move, store and load paper rolls
------------	---

#### Electrical & Air

Power	400-480 Vac, 3-phase, 50/60 Hz, 10 A	
Consumption	2400 W (in use), 500 W (idle)	
Heat output	1530 BTU/h, 450 W	
Air	6 - 8 bar	

#### Environmental

Temperature	60 - 90° F	15 - 32° C
Acoustics	65 dB(A)	
Humidity	50 ± 10%	

#### Dimensions

Length (Excl. max roll)	79.9"	2030 mm
Width	50"	1270 mm
Height (incl. display)	51.5"	1300 mm
Weight	2880 lb	1306 kg
Color	Dark Grey	

#### Approvals

CE (2006/42/EC), EMC Class A, LVD,  
CB EN 60950, cULus 60950-1,  
FCC15 Class A

Product Specification



01032016

©2016 TecnaU. All rights reserved. The TecnaU name and logo are trademarks of TecnaU. TecnaU reserves the right to make any technical amendments without prior notification.



**TECNAU**  
w w w . t e c n a u . c o m

Europe	Italy	+39 0125 631678	info.it@tecnaU.com
	Sweden	+46 372 256 00	info.se@tecnaU.com
Americas	USA	+1 978 608 0500	info.us@tecnaU.com
Asia Pacific	China	+86 159 00710147	info.cn@tecnaU.com
	Singapore	+65 6793 9478	info.sg@tecnaU.com