

# Cutter c23

## High speed cutting



- ✓ *Rotary knife for maximum precision*
- ✓ *Light weight and high speed*
- ✓ *Full bleed variable strip cut*
- ✓ *Offset on the fly*

### Service Area

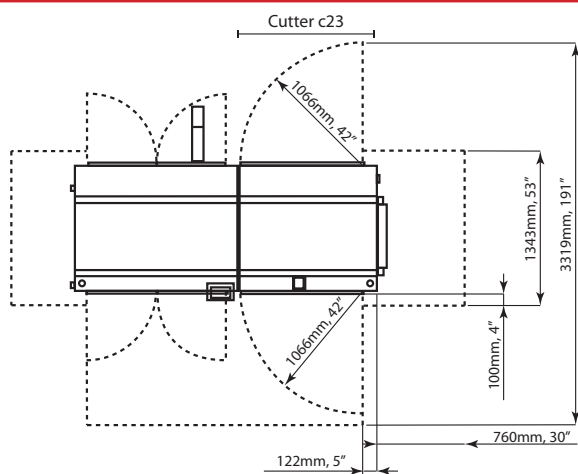

### Technical Specifications

#### Performance / Media

Speed max.	550 ft/min	168 m/min
Feeding	Pinfed or pinless	
Web infeed	1 or 2 with slit merge	
Paper weight	10.5# bond - 140# index, 40 - 250 gsm <i>(paper dependent, above 200 gsm requires application review)</i>	
Web width	5.5" - 20.5"	140 - 520 mm
Form length	8" - 18"	204 - 457 mm
Delivery height	37.4" - 41.3"	950 - 1050 mm
Strip cut	1/8" - 3/4"	3 - 19 mm
Gutter cut	6, 8, 10, 12mm	

#### Options

Interface, Trim chopper, Smart sensor (for job tracking and non-data page detection)

Center slitter (for 3-up), Antistatic equipment,

#### Electrical

Power	400 - 480 V, 3 phases, 50/60 Hz, 6 A	
Consumption	2250 W (in use)	300 W (idle)
Heat output	1750 BTU/h	

#### Environmental

Temperature	50° - 90° F	10° - 32° C
Acoustics	85 dB(A)	
Humidity	40% - 60%	

#### Dimensions

Length	42"	1066 mm
Width	45"	1142 mm
Height excl. display	46"	1165 mm
Weight	1300 lb	590 kg
Color	Gray	

#### Approvals

CE (98/37/EG), EMC Class A, LVD, CB EN 60950, cULus 1950 3rd, FCC15 Class A, VCCI

## Product Specifications



26112015

©2015 TecnaU. All rights reserved. The TecnaU name and logo are trademarks of TecnaU. TecnaU reserves the right to make any technical amendments without prior notification.



**TECNAU**  
w w w . t e c n a u . c o m

Europe	Italy	+39 0125 631678	info.it@tecnaU.com
	Sweden	+46 372 256 00	info.se@tecnaU.com
Americas	USA	+1 978 608 0500	info.us@tecnaU.com
Asia Pacific	China	+86 159 00710147	info.cn@tecnaU.com
	Singapore	+65 6793 9478	info.sg@tecnaU.com